

# Fire and Security Specification

## Object Styles Used

	<b>Fire Alarm Devices</b>	For all fire alarm devices including smoke and heat detectors
	<b>Detector Code Lines</b>	For detectors symbolic code lines (showing the reach of them)
	<b>Security Devices</b>	For all security devices, alarm controls and alarm panels
	<b>Specialty Equipment</b>	
	<b>Fire Protection</b>	For fire protection elements including fire hose reels and fire extinguishers
	<b>Sprinklers</b>	For all fire sprinklers
	<b>Sprinkler Code Lines</b>	For fire sprinklers symbolic code lines (showing the reach of the sprinkler)

	<b>Generic Annotations</b>
	<b>Fire Symbols</b>
	<b>Security Symbols</b>
	<b>Symbol Leaders</b>
	<b>Detail Items</b>
	<b>Security Devices</b>

Allows for amendments of the lineweights and colours to all the linework within the symbols and leaders.

Allows for amendments of the lineweights and colours of all the linework within the real-size alarm board symbols.

## Detail Levels - all Fire and Security items

3d				The fine detail within the smaller objects (as shown in example) are created with model lines and/or model text. They will show on 3ds and elevations when the views visual style is set to wireframe, hidden, shaded, consistent colours or realistic and the detail level is set to "Fine"
Elevation				
Plan				

All plan representation is as follows:  
 Coarse detail level: Symbol only  
 Medium detail level: Symbol and object  
 Fine detail level: Object only

## Detail Levels - Alarm Boards

### ELEVATIONS AND 3D DETAIL LEVELS

Model and clearance zones show in Medium and Fine modes  
 Symbol shows in Medium and Coarse modes  
 Outline shows in 3d Coarse mode

<b>Coarse:</b> Plan real size symbol only shown	<b>Medium:</b> Plan real size symbol and real size unit shown	<b>Fine:</b> Plan real size unit shown

## Use of Shared Symbol Families and Schedules

A lot of the symbols within the families require a certain set-up process to allow them to show on walls as well as on ceilings and also allows them to have automatic wall-ceiling symbol interchange.

This set-up process requires them to be "shared" families.

One of the implications of sharing these nested families is that these symbols and light sources will schedule with the real fittings (resulting in double counting).

To counter this, all the shared symbol families have as many of their parameter values as possible assigned to "Symbol Only" - allowing you to filter them out from within your schedule so they are disregarded.

All of these symbols also appear within your project browser: their names all begin with "Symbol."

- 
- 
- 
- 

Example of shared symbol family naming

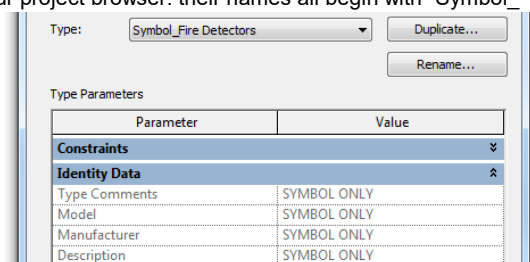

Parameter	Value
<b>Constraints</b>	
<b>Identity Data</b>	
Type Comments	SYMBOL ONLY
Model	SYMBOL ONLY
Manufacturer	SYMBOL ONLY
Description	SYMBOL ONLY

Example of shared symbol family parameter values

# Fire and Security Specification

## Common Instance Parameters

The Properties window for 'FIRE - Manual Call Point' shows the following parameters and their effects:

- Constraints:** Host (Basic W...), Elevation (40.000), Offset (0.000)
- Graphics:** Plan Symbol Offset Right (checked), Plan Symbol Offset Left (unchecked), Plan Symbol Offset Factor (0.125), Plan Symbol Leader (checked)
- Text:** Show Reported Elevation (checked), Reported Elevation (40.000)
- Other:** Cut Plane Extension UP (60.000), Cut Plane Extension DOWN (8.000), Allow Cut Plane Extensions (unchecked), Schedule Level (SECURIT...)

Graphical effects shown to the right include:
 

- Two bell symbols.
- Two square symbols with 'FIRE' text, one with a leader line.
- A square symbol with a circle inside and '(40)' below it.
- A square symbol with a dashed line above it labeled 'RCP Cut Plane' and a dashed line below it labeled 'Floor Plan Cut Plane'.

Plan Symbol Offsets and Leaders allow you to correctly document fixtures that are aligned vertically. These parameters are not available for sprinklers and fire hose reels.

The Revit standard "Elevation" parameter cannot currently be used in labels, tags or schedules. To overcome this limitation use the "Reported Elevation" parameter. The RevitWorks Elevation Reporter add-in (Premium version only) ensures that the "Elevation" and the "Reported Elevation" parameters are always synchronised. If the add-in is not loaded you will need to manually update it.

Cut Plane Extensions allow you to show low level components on your Reflected Ceiling Plans and high level components on your Floor Plans.

## Common Type Parameters

The Type Properties window for 'FIRE - Manual Call Point' shows the following parameters and their effects:

- Symbol Fill:** A checkbox that, when checked, allows for different fill colors (white, black, grey) for the fixture symbol.
- Fixture Label:** A checkbox that, when checked, adds the text 'MCP' as a label to the fixture symbol.

Graphical effects shown to the right include:
 

- A row of four symbols: a white circle, a black circle, a grey circle, and a bell symbol.
- A row of two symbols: a white circle with 'MCP' text below it, and a grey circle with 'MCP' text below it.

All fixtures come with symbol fill options allowing for more graphical differentiation where required.





"Show Fixture Label" shows the "Fixture Label" text parameter as an annotation label within the family.

These labels are in a set position relative to the symbol and rotate with the family while staying readable.





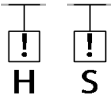













Alternatively, you could turn this off and tag your family which gives greater flexibility in the positioning and orientation of the label.

# Fire and Security Specification



## Fire Alarm Devices

	3d	Wall Symbol	Ceiling Symbol
 FIRE - Detectors			
Heat Detector		H	
Smoke Detector		S	





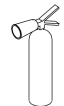

## Fire Alarm Devices (Premium only)

 FIRE - Manual Call Point			
FIRE - Manual Call Point			
 FIRE - Sounder Horn			
FIRE - Sounder Horn			
 FIRE - Sounder Speaker			
5.5"Ø			
7"Ø			
 FIRE - Sounder Wall Plate			
FIRE - Sounder Wall Plate			
 FIRE - Strobe			
4" x3.5"h			

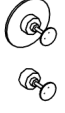
## Fire Controllers

	3d	Wall Symbol	Ceiling Symbol
 FIRE - Extinguisher			
FIRE - Extinguisher			

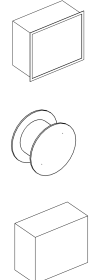
## Fire Controllers (Premium only)

 FIRE - Sprinklers			
With Escutcheon			
Without Escutcheon			
 FIRE - FHR			
Recessed Cabinet			
Reel Only			
Surface Mounted cabinet			

### NOTES!

1. 3d images as shown are in detail level "Fine mode"
2. Wall and ceiling symbols as shown are in detail level "Coarse" mode
3. All symbols can have labels added.
4. Labels as shown in images are the out-of-the-box defaults and can be easily changed or turned on/off from within the fixtures type properties (refer previous page for screenshot)

## Additional Feature for Fire Sprinklers

All sprinklers have the ability to show the extent of the sprinklers reach by setting code line type parameters within the family and ticking the "Show Design Code Lines" instance parameter. These lines are on their own sub-category (as shown on page 1. "Object Styles Used") so can be turned off view-wide where required.

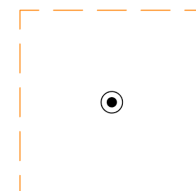
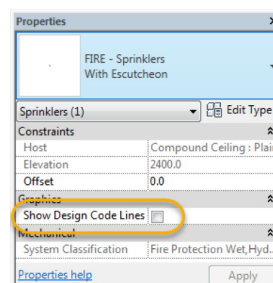









Content that works



















































[www.revitworks.com](http://www.revitworks.com)

# Fire and Security Specification

## Security Devices

	3d	Wall Symbol	Ceiling Symbol
 SECURITY - Sounder and Strobe SECURITY - Sounder and Strobe			
 SECURITY - Strobe 4" x3.5"h			

## Security Devices (Premium only)

 SECURITY - Breakglass SECURITY - Breakglass			
 SECURITY - Camera Ceiling Mounted Wall Mounted	 		
 SECURITY - Camera Enclosed 5"Ø			
 SECURITY - Credential Reader 3.25" x3.25" x0.75"d			
 SECURITY - Door Release Push Button SECURITY - Door Release Push Button			
 SECURITY - Door Release Request to Exit SECURITY - Door Release Request to Exit			
 SECURITY - Keypad 3.5"x5"hx1"d 7.5"x5.5"hx1"d	 	 	
 SECURITY - PIR Sensor 4"			
 SECURITY - PIR Sensor Directional Ceiling 2.5"w x4"d Wall 2.5"w x4"d	 	 	 
 SECURITY - Sounder Horn SECURITY - Sounder Horn			
 SECURITY - Sounder Speaker 5.5"Ø 7"Ø	 	 	 
 SECURITY - Sounder Wall Plate SECURITY - Sounder Wall Plate			

### NOTES!

1. 3d images as shown are in detail level "Fine mode"
2. Wall and ceiling symbols as shown are in detail level "Coarse" mode
3. All symbols can have labels added.
4. Labels as shown in images are the out-of-the-box defaults and can be easily changed or turned on/off from within the fixtures type properties (refer previous page for screenshot)

# Fire and Security Specification

## Alarm Panels

Refer page 1 for explanation of how symbols work at different detail levels.

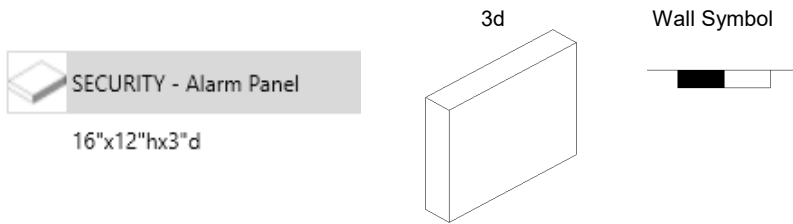

## Fire Panels (Premium only)

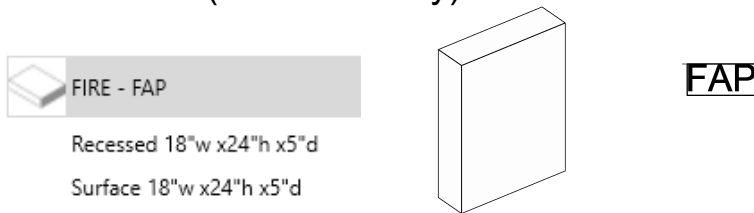

## Alarm Controls (Premium only)

Alarm controls have no modelled elements but come with the correct security connectors and can be scheduled. To create more controls, duplicate existing type, change the label and select a square or circular border as per image

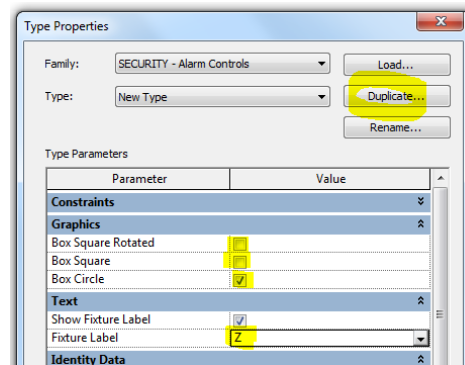
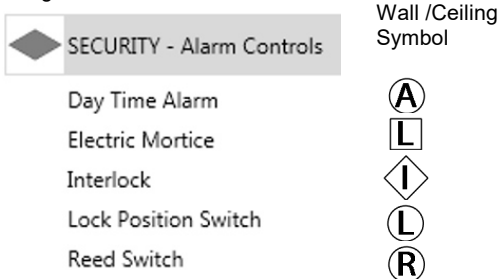

## Magnetic Locks (Premium only)

Magnetic locks have modelled elements. They can be placed on any surface. If placed on a vertical surface (i.e. a wall), ensure "Wall Mounted" tickbox is ticked as per the image to ensure that the modelled elements are in the correct orientation:

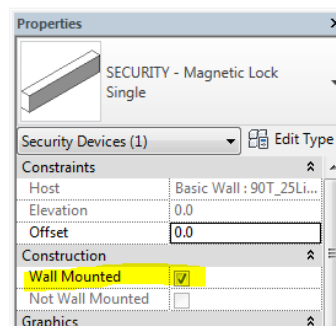
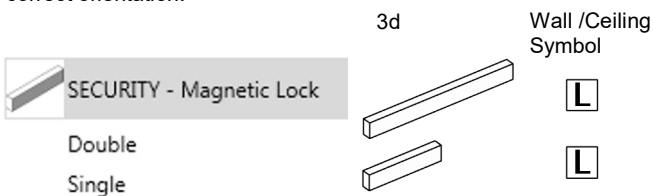

### NOTES!

- 3d images as shown are in detail level "Fine mode"
- Wall and ceiling symbols as shown are in detail level "Coarse" mode
- All symbols can have labels added.
- Labels as shown in images are the out-of-the-box defaults and can be easily changed or turned on/off from within the fixtures type properties (refer previous page for screenshot)